

1020

DWG. NO.

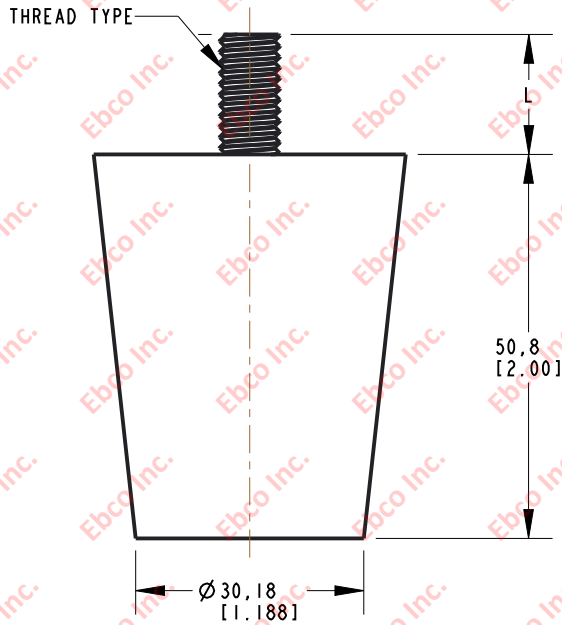
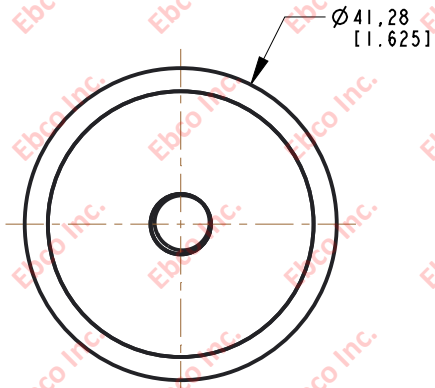

HARDWARE SPECIFICATIONS

PART NO.	THREAD TYPE	L
1020-XX-F5	5/16-18	15,9 [1.625]

AXIAL COMPRESSION SPECIFICATIONS

PART NUMBER		MAX. RECOMMENDED STATIC LOAD		REFERENCE STIFFNESS	
NATURAL RUBBER	NEOPRENE	lb	N	lb/in	N/mm
1020-73-XX	1020-83-XX	75	333	375	66



TITLE:	1020
THE INFORMATION CONTAINED IN THIS DRAWING IS THE SOLE PROPERTY OF EBCO ANY REPRODUCTION IN PART OR AS A WHOLE WITHOUT THE WRITTEN PERMISSION OF EBCO IS PROHIBITED.	
TOLERANCES PER RMA STANDARD A3	REV. B
DATE: 06-14-21	UNITS: mm [INCH]
1330 HOLMES RD. ELGIN, IL 60123	
SPECIFICATIONS SUBJECT TO CHANGE	