

1031

DWG. NO.

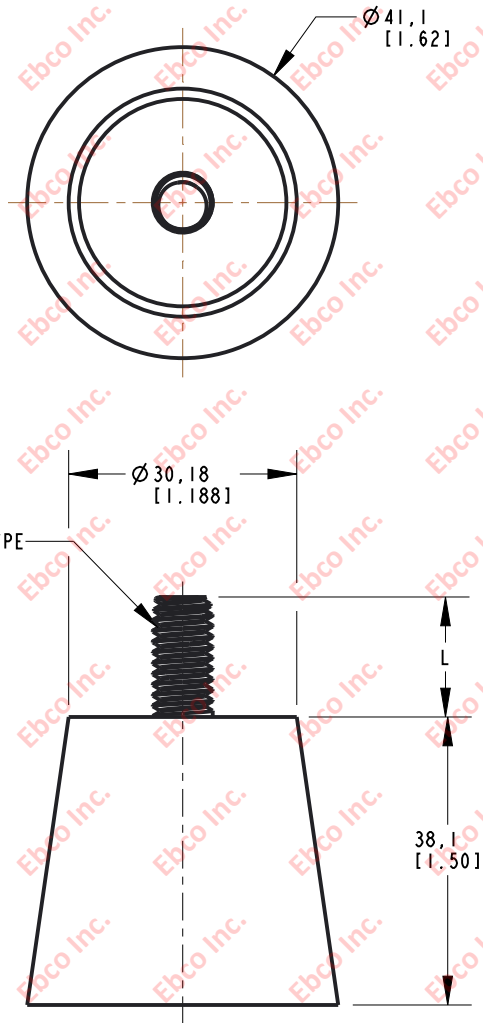

HARDWARE SPECIFICATIONS

PART NO.	THREAD TYPE	L
1031-XX-F5	5/16-18	15,9 [.625]
1031-XX-F7	5/16-18	22,23 [.875]

AXIAL COMPRESSION SPECIFICATIONS

PART NUMBER		MAX. RECOMMENDED STATIC LOAD		REFERENCE STIFFNESS	
NATURAL RUBBER	NEOPRENE	lb	N	lb/in	N/mm
1031-73-XX	1031-83-XX	80	356	530	93
1031-77-XX	1031-87-XX	200	890	1333	234



TITLE: 1031

THE INFORMATION CONTAINED IN THIS DRAWING IS THE SOLE PROPERTY OF EBCO. ANY REPRODUCTION IN PART OR AS A WHOLE WITHOUT THE WRITTEN PERMISSION OF EBCO IS PROHIBITED.

TOLERANCES PER RMA STANDARD A3	REV. C	DATE: 06-14-21
		UNITS: mm [INCH]

1330 HOLMES RD. ELGIN, IL 60123

SPECIFICATIONS SUBJECT TO CHANGE