

1110

DWG. NO.

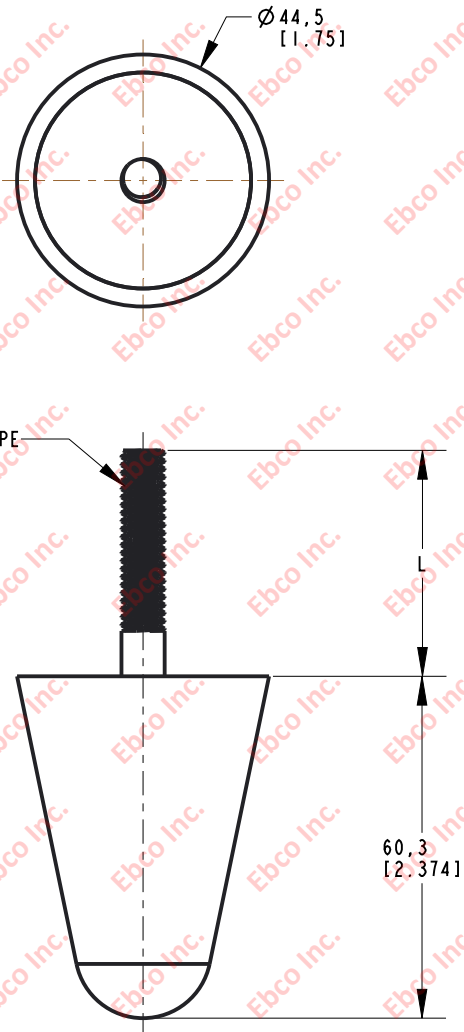

**HARDWARE SPECIFICATIONS**

PART NO.	THREAD TYPE	L
1110-XX-F5	5/16-18	15,9 [.625]
1110-XX-H15	3/8-16	42,0 [1.65]
1110-XX-Q15	M10X1.5	42,0 [1.65]

**AXIAL COMPRESSION SPECIFICATIONS**

PART NUMBER		MAX. RECOMMENDED STATIC LOAD		REFERENCE STIFFNESS	
NATURAL RUBBER	NEOPRENE	lb	N	lb/in	N/mm
1110-71-XX	1110-81-XX	20	89	80	14
1110-73-XX	1110-83-XX	35	156	140	25
1110-75-XX	1110-85-XX	55	245	220	39



TITLE: 1110	
THE INFORMATION CONTAINED IN THIS DRAWING IS THE SOLE PROPERTY OF EBCO. ANY REPRODUCTION IN PART OR AS A WHOLE WITHOUT THE WRITTEN PERMISSION OF EBCO IS PROHIBITED.	
TOLERANCES PER RMA STANDARD A3	REV. C
DATE: 06-14-21	UNITS: mm [INCH]

1330 HOLMES RD. ELGIN, IL 60123

SPECIFICATIONS SUBJECT TO CHANGE