

4305

DWG. NO.

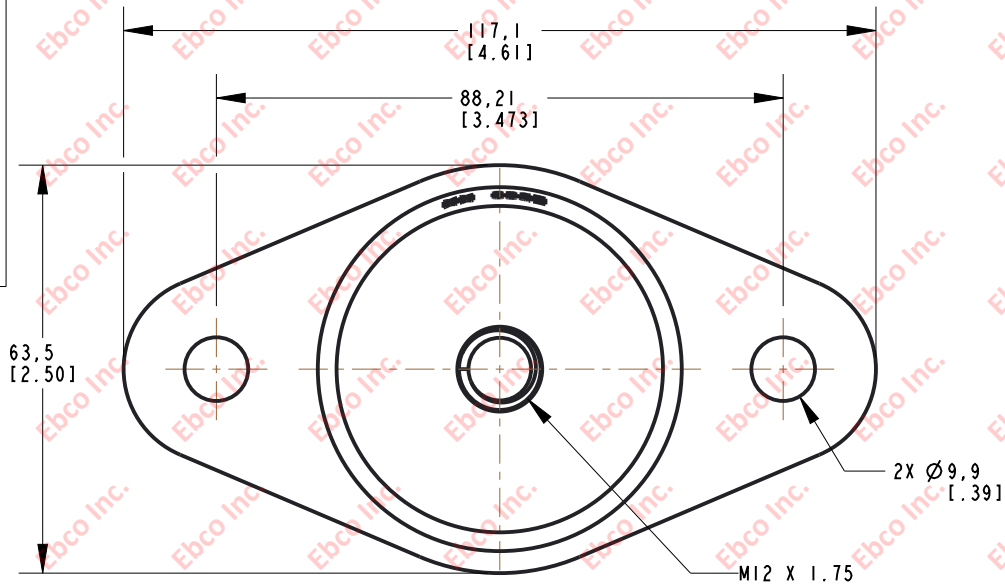

INSTALLATION VIEW (Shown under no load)

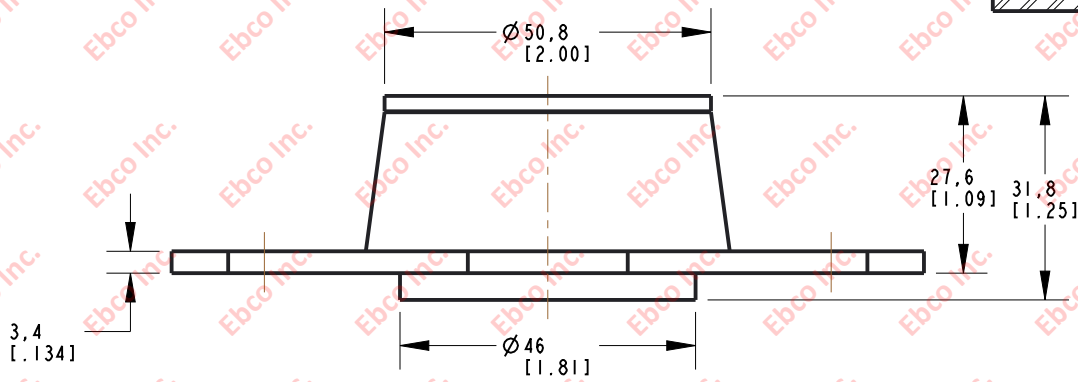
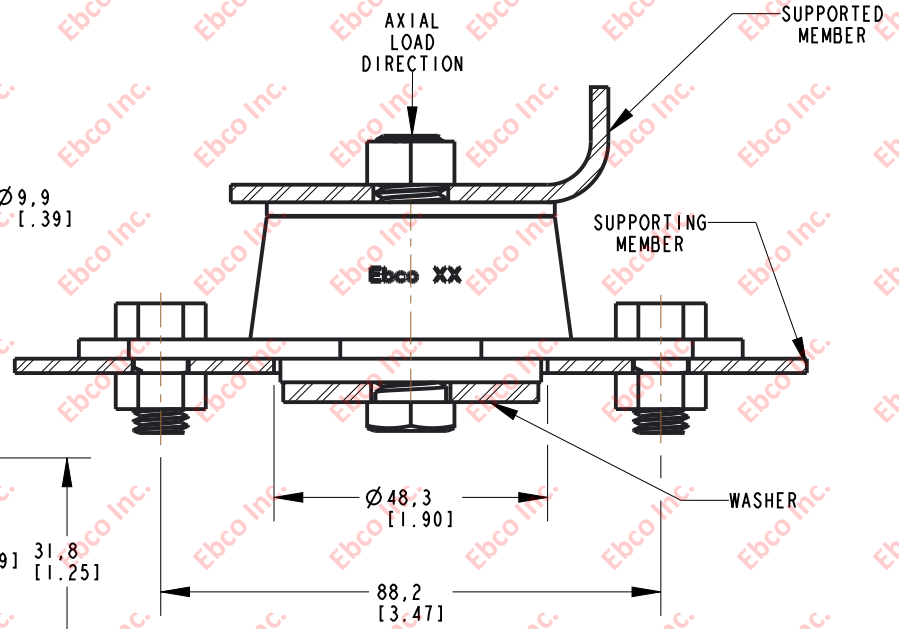

INSTALLATION DIMENSIONS

RECOMMENDED BOLT INFORMATION		TIGHTENING TORQUE			
		CLAMP LOAD		TIGHTENING TORQUE	
SIZE	CLASS	lb	N	ft-lb	N-m
M12	9.8	9046	40239	75.4	101.8

WASHER SPECIFICATIONS					
O. D.		I. D.		THICKNESS	
in	mm	in	mm	in	mm
1.77	45	.55	14	.14	3.5

SPECIFICATIONS

PART NUMBER		MAX. AXIAL DEFLECTION		MAX. AXIAL LOAD	
NATURAL RUBBER	NEOPRENE	in	mm	lb	N
4305-77	4305-87	.10	2.54	390	1735
4305-78	4305-88			450	2002



TITLE:	4305
THE INFORMATION CONTAINED IN THIS DRAWING IS THE SOLE PROPERTY OF EBCO. ANY REPRODUCTION IN PART OR AS A WHOLE WITHOUT THE WRITTEN PERMISSION OF EBCO IS PROHIBITED.	
TOLERANCES PER RMA STANDARD	REV. C
A3	DATE: 06-04-21
	UNITS: mm [INCH]
1330 HOLMES RD. ELGIN, IL 60123	

SPECIFICATIONS SUBJECT TO CHANGE