

4731

DWG. NO.

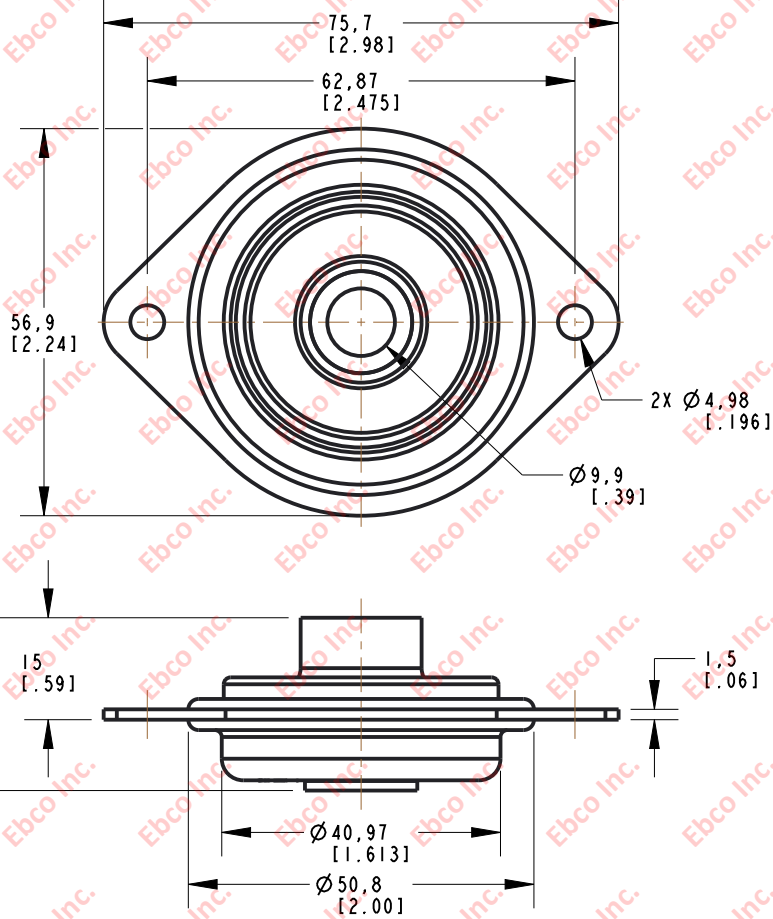

INSTALLATION VIEW (Shown under no load)

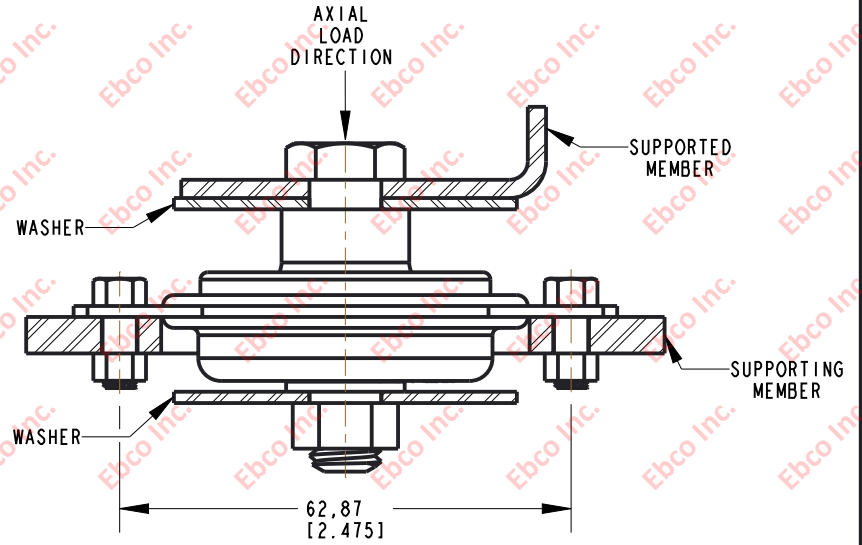

INSTALLATION DIMENSIONS

SPECIFICATIONS

PART NUMBER		MAX. AXIAL DEFLECTION		MAX. AXIAL LOAD	
NATURAL RUBBER	NEOPRENE	in	mm	lb	N
4731-700	4731-800	0.18	4.57	15	67
4731-71	4731-81			20	89
4731-73	4731-83			30	133
4731-74	4731-84			40	178
4731-75	4731-85			50	222
4731-76	4731-86			65	289

RECOMMENDED BOLT INFORMATION				TIGHTENING TORQUE			
ENGLISH		METRIC		CLAMP LOAD		TIGHTENING TORQUE	
SIZE	GRADE	SIZE	CLASS	lb	N	ft-lb	N-m
3/8	5	M8	9.8	4941	17800	30.9	28.5
WASHER SPECIFICATIONS							
O.D.		I.D.		THICKNESS			
in	mm	in	mm	in	mm		
1.88	47.80	.39	9.90	.06	1.50		



TITLE:	4731		
THE INFORMATION CONTAINED IN THIS DRAWING IS THE SOLE PROPERTY OF EBCO ANY REPRODUCTION IN PART OR AS A WHOLE WITHOUT THE WRITTEN PERMISSION OF EBCO IS PROHIBITED.			
TOLERANCES PER RMA STANDARD A3	REV. F	DATE: 06-07-21	UNITS: mm [INCH]
1330 HOLMES RD. ELGIN, IL 60123			
SPECIFICATIONS SUBJECT TO CHANGE			