

4740

DWG. NO.

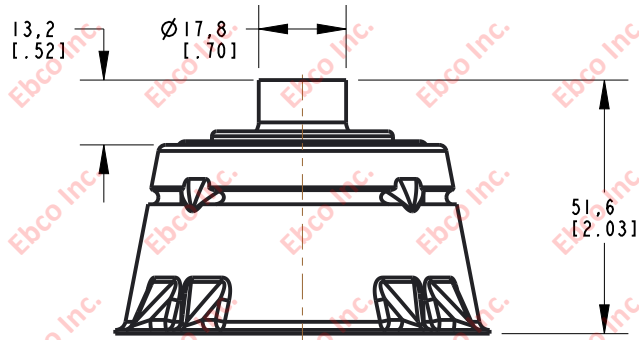

INSTALLATION VIEW (Shown under no load)

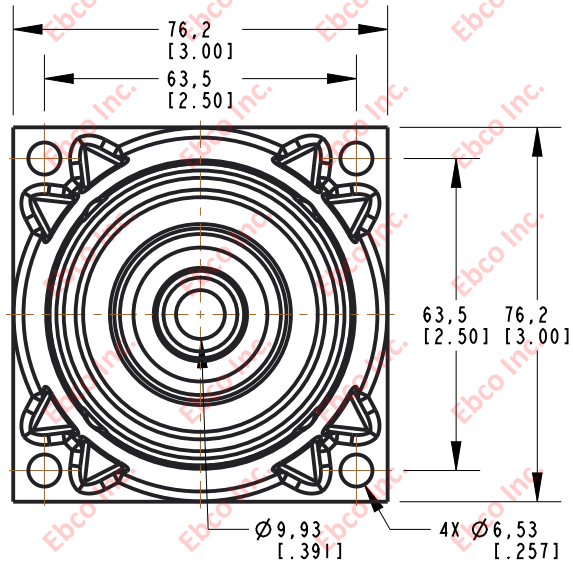
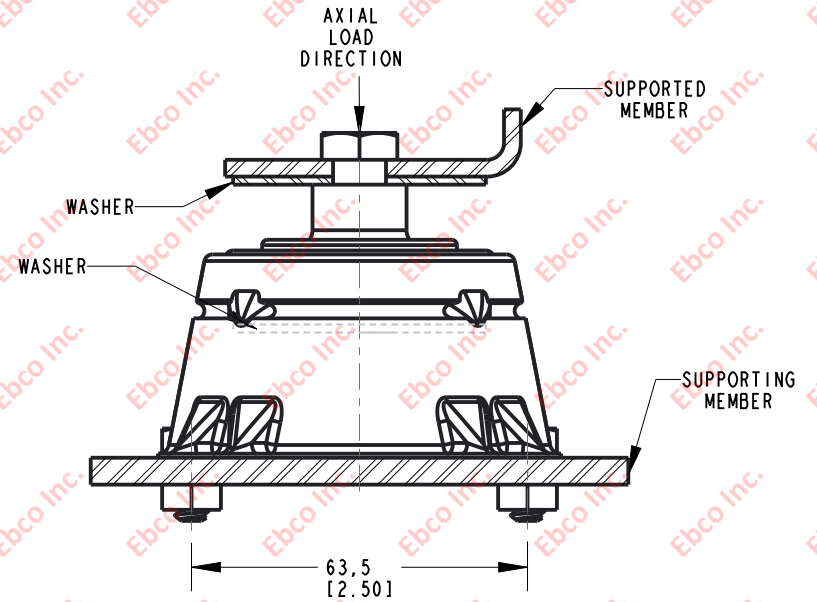

INSTALLATION DIMENSIONS

RECOMMENDED BOLT INFORMATION				TIGHTENING TORQUE			
ENGLISH		METRIC		CLAMP LOAD		TIGHTENING TORQUE	
SIZE	GRADE	SIZE	CLASS	lb	N	ft-lb	N-m
3/8	5	M10	9.8	4941	21979	30.9	41.9
WASHER SPECIFICATIONS							
O. D.		I. D.		THICKNESS			
in	mm	in	mm	in	mm		
1.88	47.80	.39	9.90	.06	1.50		

SPECIFICATIONS

PART NUMBER		MAX. AXIAL DEFLECTION		MAX. AXIAL LOAD	
NATURAL RUBBER	NEOPRENE	in	mm	lb	N
4740-76	4740-86	0.19	4.83	50	222
4740-77	4740-87			65	342
4740-78	4740-88			80	421



TITLE:	4740		
THE INFORMATION CONTAINED IN THIS DRAWING IS THE SOLE PROPERTY OF EBCO ANY REPRODUCTION IN PART OR AS A WHOLE WITHOUT THE WRITTEN PERMISSION OF EBCO IS PROHIBITED.			
TOLERANCES PER RMA STANDARD	REV. C	DATE: 06-07-21	UNITS: mm [INCH]
A3			
1330 HOLMES RD. ELGIN, IL 60123			
SPECIFICATIONS SUBJECT TO CHANGE			